

THIS DRAWING IS UNPUBLISHED. RELEASED FOR PUBLICATION
 © COPYRIGHT BY TYCO ELECTRONICS CORPORATION. ALL RIGHTS RESERVED.

| LOC | DIST | REVISIONS | | | | | |
|-----|------|-----------|-----|-----------------------|---------|-----|------|
| AF | 50 | P | LTR | DESCRIPTION | DATE | DWN | APVD |
| | | A2 | | REV PER ECR 07-027465 | 14NOV07 | JR | PD |

- CONTINUOUS STRIP ON REELS
- MATING TAB THK TO BE 0.635 ± 0.025 $[\.025 \pm .001]$
- WIRE SIZE IS $[\#22 - \#18]$ AWG.
- INSULATION RANGE IS 1.52-2.54 $[\.060 - .100]$ DIA.

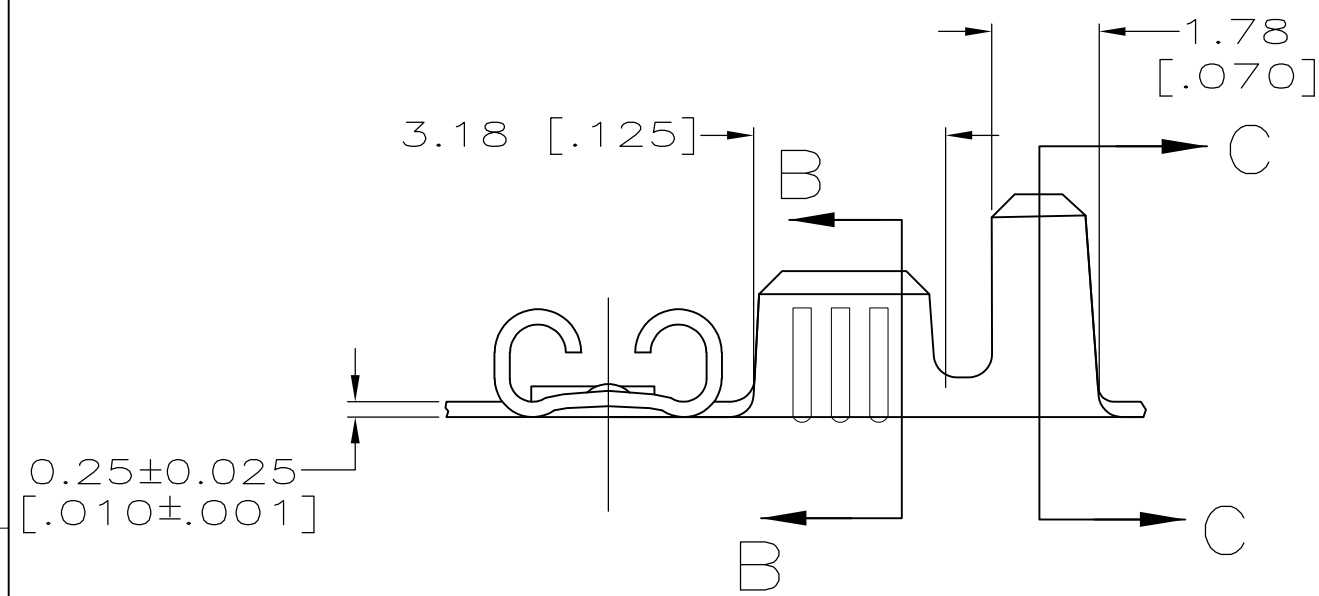
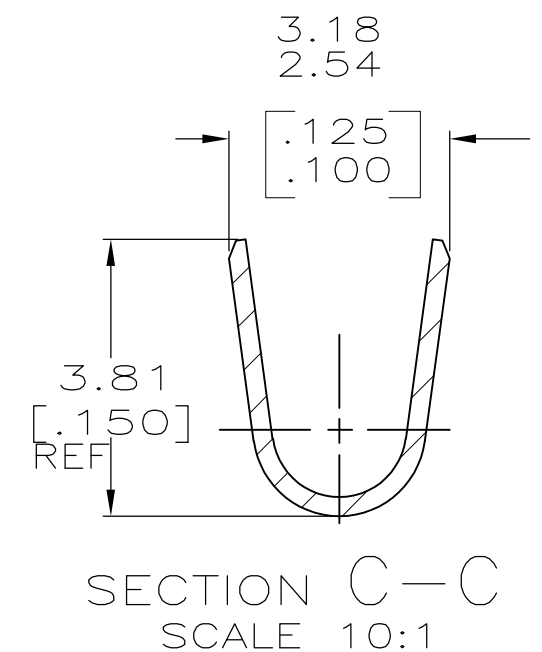
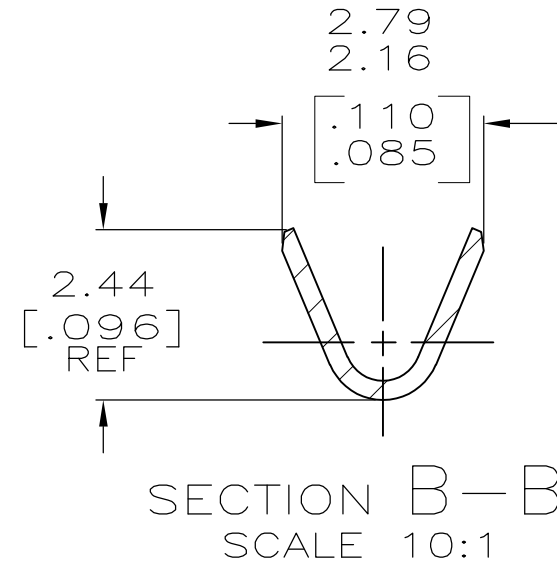
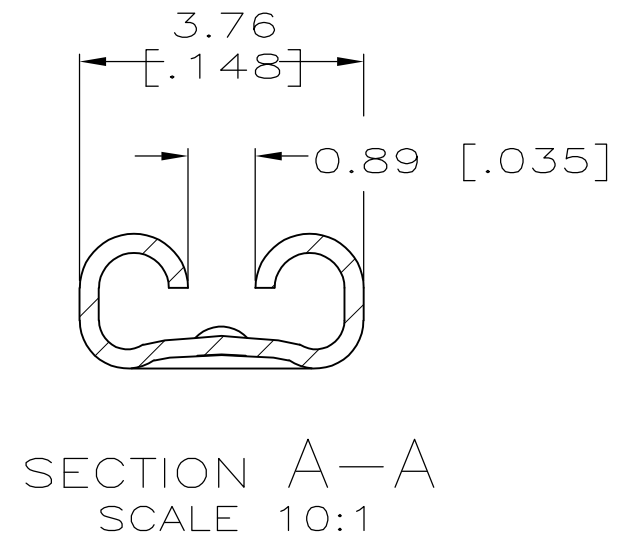
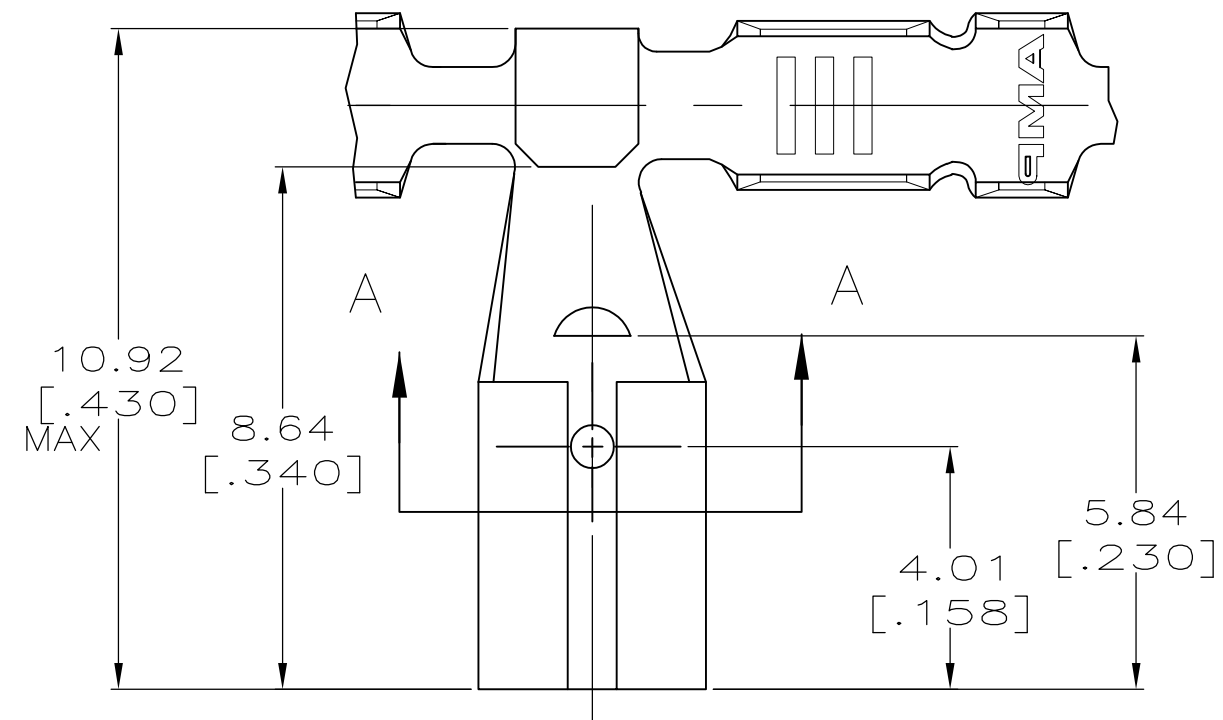

1217138-1
PART NO.

| | | | | | | | | | | | | | | | | | | | |
|--|---------------|----------------------------|---|--------------|-----------------|------------------|-----|-------|---------------|-------|-----|--------|-----|-----------------------|--|------------|--------------------|-------------------------|--------------------|
| THIS DRAWING IS A CONTROLLED DOCUMENT. | | DWN JR RUTH 3FEB99 | Tyco Electronics Corporation Harrisburg, PA 17105-3608 | | | | | | | | | | | | | | | | |
| DIMENSIONS: MM [INCHES] | | CHK MS FEHER 3FEB99 | NAME RECEPTACLE, FASTON, FLAG, 2.79 [.110] SERIES | | | | | | | | | | | | | | | | |
| TOLERANCES UNLESS OTHERWISE SPECIFIED: | | APVD S HEADER 3FEB99 | PRODUCT SPEC - | | | | | | | | | | | | | | | | |
| <table border="0"> <tr><td>0 PLC</td><td>± -</td></tr> <tr><td>1 PLC</td><td>± -</td></tr> <tr><td>2 PLC</td><td>± -</td></tr> <tr><td>3 PLC</td><td>± 0.25 [.010]</td></tr> <tr><td>4 PLC</td><td>± -</td></tr> <tr><td>ANGLES</td><td>± -</td></tr> </table> | | 0 PLC | ± - | 1 PLC | ± - | 2 PLC | ± - | 3 PLC | ± 0.25 [.010] | 4 PLC | ± - | ANGLES | ± - | APPLICATION SPEC - | | SIZE A3 | CAGE CODE 00779 | DRAWING NO C-1217138 | RESTRICTED TO - |
| 0 PLC | ± - | | | | | | | | | | | | | | | | | | |
| 1 PLC | ± - | | | | | | | | | | | | | | | | | | |
| 2 PLC | ± - | | | | | | | | | | | | | | | | | | |
| 3 PLC | ± 0.25 [.010] | | | | | | | | | | | | | | | | | | |
| 4 PLC | ± - | | | | | | | | | | | | | | | | | | |
| ANGLES | ± - | | | | | | | | | | | | | | | | | | |
| MATERIAL H04 BRASS | | FINISH PRE-TIN | | WEIGHT - | | CUSTOMER DRAWING | | | | | | | | | | | | | |
| | | | | SCALE 8:1 | SHEET 1 OF 1 | REV A2 | | | | | | | | | | | | | |